

REVISION HISTORY				
REV.	DESCRIPTION	DATE	ECO	BY

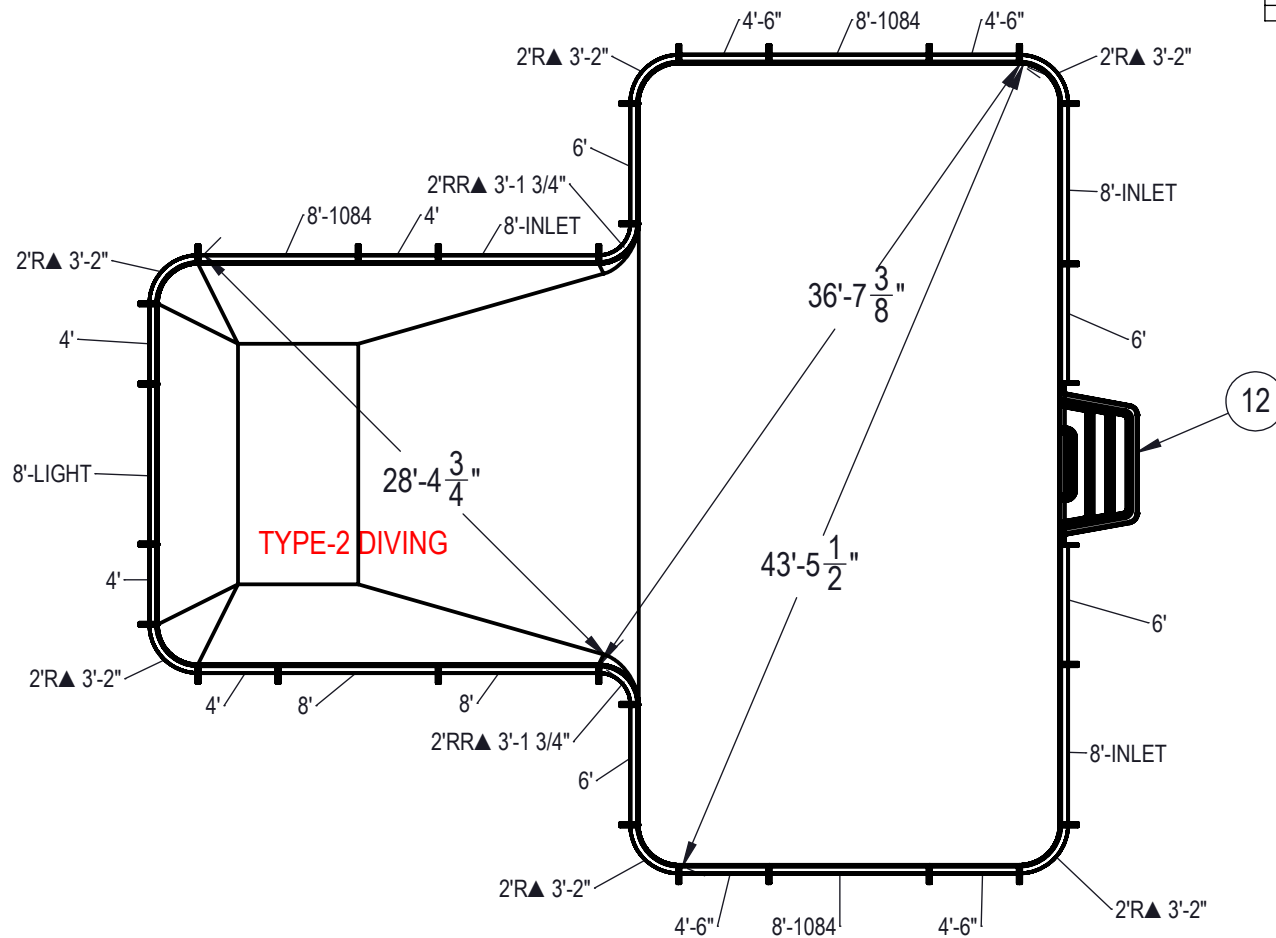

NOTES:

- THESE ARE FINISHED DIMENSIONS READY FOR THE LINER.
- DIMENSIONS ARE FROM INSIDE POOL PANELS.
- ROPE AND FLOAT ASSEMBLY SHOULD BE INSTALLED IN ACCORDANCE WITH CURRENT ANSI/ASPS/ICC REGULATIONS
- HYDRA LINER TRACK FOR STEPS IS INSTALLED WITH THE BARB FACING THE RISER WALL ON THE STEP.

EXCAVATION NOTES:

- ROUGH EXCAVATION SHOULD BE 2" DEEPER IN EACH INSTANCE.
- SOIL TO HAVE MINIMUM BEARING CAPACITY OF 1500 PSF.
- LOCATE TOP OF POOL AT LEAST 6" ABOVE THE SURROUNDING LAND ELEVATION.
- SEE "OVER DIG DETAIL" FOR EXCAVATION AROUND POOL.
- FILL VOIDS UNDER BASE OF PANELS AND TAMP WELL.
- BACK FILL WITH NON-EXPANSIVE MATERIAL.
- FOLLOW ALL CURRENT ANSI / APSP / ICC GUIDELINES FOR RESIDENTIAL POOLS

IMPORTANT NOTES:

THIS DOCUMENT IS FOR ILLUSTRATIVE PURPOSES ONLY. THE DEALER OR CONTRACTOR WHO SELLS OR INSTALLS YOUR POOL IS AN INDEPENDENT CONTRACTOR AND IS NOT AN AGENT OF THE MANUFACTURER. THE CONSTRUCTION METHODS ILLUSTRATED HERE ARE SUGGESTIONS AND APPLY ONLY TO NORMAL GROUND CONDITIONS. THERE MAY BE ADDITIONAL PRECAUTIONS AND/OR METHODS OF CONSTRUCTION. PROPER INSTALLATION IS THE RESPONSIBILITY OF THE DEALER/BUILDER/CONTRACTOR.

ITEM	FILE NAME	DESCRIPTION	CUSTOMER DRAWING #	VENDOR PART #	QTY.
1	BOLT, PACK	BOLT, FLANGE, 3/8-16 X 1", PACK (50)	HPS1916	HPS1916	7
2	SBRACE	BRACE, FOLD OVER WITH TURNBUCKLE, STEEL, HPSFOB	HPSFOB	HPSFOB	30
3	PANEL, RADIUS	PANEL, 2' RADIUS, 3-2" LONG, 600 SERIES	HPSD2R	00000287	6
4	PANEL, RR	PANEL, 2' REVERSE RADIUS, 3'-1 3/4" LONG, 600 SERIES	HPSD2RR	00000288	2
5	PANEL, STRAIGHT	PANEL, 4' LONG, 600 SERIES	HPSD104P	00000274	4
6	PANEL, STRAIGHT	PANEL, 4'-6" LONG, 600 SERIES	HPSD1046P	00000644	4
7	PANEL, STRAIGHT	PANEL, 6' LONG, 600 SERIES	HPSD106P	00000676	4
8	PANEL, STRAIGHT	PANEL, 8' LONG, 1084, 600 SERIES	HPSD10884	00002006	3
9	PANEL, STRAIGHT	PANEL, 8' LONG, 600 SERIES	HPSD108P	00000687	2
10	PANEL, STRAIGHT	PANEL, 8' LONG, INLET, 600 SERIES	HPSD108I	00000699	3
11	PANEL, STRAIGHT	PANEL, 8' LONG, LIGHT, 600 SERIES	HPSD108L	00000701	1
12	HS110N	STEP, 8", TWIN SEAT, 4 TREAD	HS110N	HS110N	1

ENGINEERING DRAWING NUMBER: 00017153	WEIGHT: 471264.5 lbs	UNLESS OTHERWISE SPECIFIED DIMENSIONS ARE IN INCHES TOLERANCES DECIMALS: X ± .1 XX ± .01 XXX ± .001 XXXX ± .0005 ANGULAR: X ± 0.5 THIRD ANGLE PROJECTION
	VOLUME: Inch ³	
	COLOR:	
	HEAT TREAT:	
	FINISH:	
	TEXTURE:	

DESIGNED BY: BUMPHREY	CREATION DATE: 9/9/2013
DETAILED BY: BUMPHREY	DETAILED DATE: 1/8/2018
LAST REVISED BY: bumphrey	LAST REVISED DATE: 1/8/2018
MATERIAL:	

HYDRA POOLS	
TITLE: LAYOUT, 20' X 45' X 40', TEE, 2' RADIUS, 8' DEEP, HS110N, LIGHT, 3-1084, 3-INLET, 600 SERIES	
PART NUMBER: 00017153	SCALE: 1:192 SHEET: 1 OF 4 SIZE: A

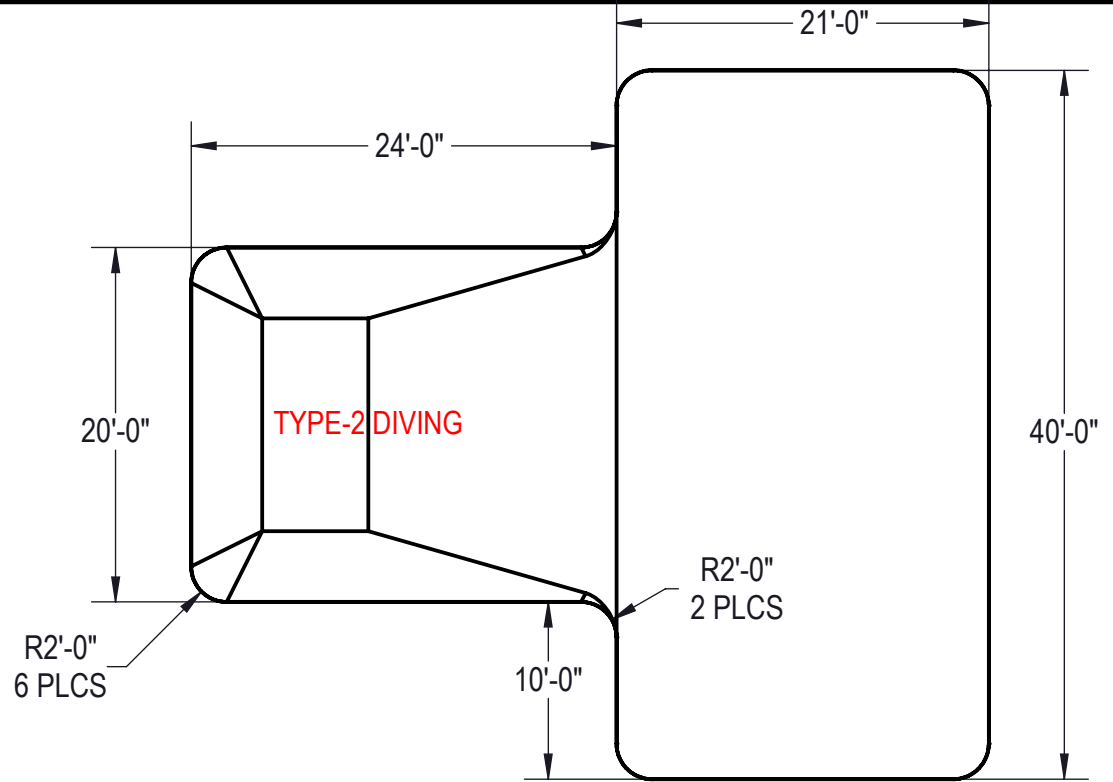
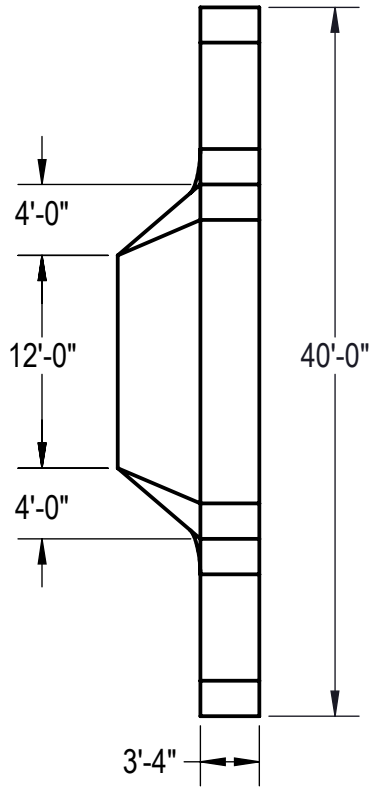

Area: 1316.57ft ^2
Perimeter: 163.13ft
Volume = 41607 US gallons

NOTES:

1. THESE ARE FINISHED DIMENSIONS READY FOR THE LINER.
2. DIMENSIONS ARE FROM INSIDE POOL PANELS.
3. ROPE AND FLOAT ASSEMBLY SHOULD BE INSTALLED IN ACCORDANCE WITH CURRENT ANSI/ASPS/ICC REGULATIONS
4. HYDRA LINER TRACK FOR STEPS IS INSTALLED WITH THE BARB FACING THE RISER WALL ON THE STEP.

EXCAVATION NOTES:

5. ROUGH EXCAVATION SHOULD BE 2" DEEPER IN EACH INSTANCE.
6. SOIL TO HAVE MINIMUM BEARING CAPACITY OF 1500 PSF.
7. LOCATE TOP OF POOL AT LEAST 6" ABOVE THE SURROUNDING LAND ELEVATION.
8. SEE "OVER DIG DETAIL" FOR EXCAVATION AROUND POOL.
9. FILL VOIDS UNDER BASE OF PANELS AND TAMP WELL.
10. BACK FILL WITH NON-EXPANSIVE MATERIAL.
11. FOLLOW ALL CURRENT ANSI / APSP / ICC GUIDELINES FOR RESIDENTIAL POOLS

IMPORTANT NOTES:

THIS DOCUMENT IS FOR ILLUSTRATIVE PURPOSES ONLY. THE DEALER OR CONTRACTOR WHO SELLS OR INSTALLS YOUR POOL IS AN INDEPENDENT CONTRACTOR AND IS NOT AN AGENT OF THE MANUFACTURER. THE CONSTRUCTION METHODS ILLUSTRATED HERE ARE SUGGESTIONS AND APPLY ONLY TO NORMAL GROUND CONDITIONS. THERE MAY BE ADDITIONAL PRECAUTIONS AND/OR METHODS OF CONSTRUCTION. PROPER INSTALLATION IS THE RESPONSIBILITY OF THE DEALER/BUILDER/CONTRACTOR.

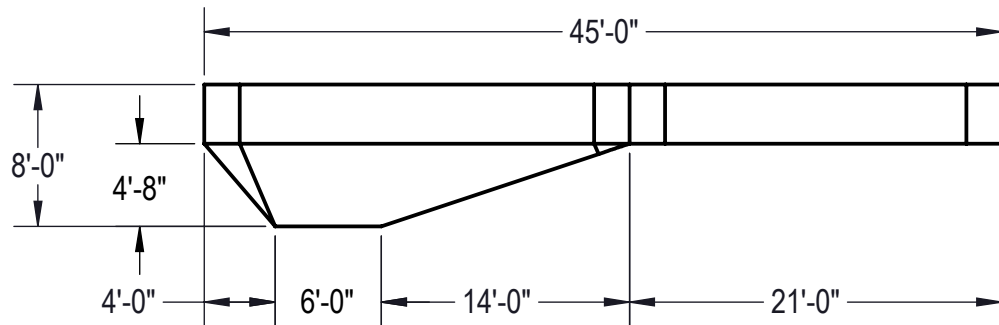

ENGINEERING DRAWING NUMBER: 00017153	WEIGHT: 347231.255 lbs	UNLESS OTHERWISE SPECIFIED DIMENSIONS ARE IN INCHES TOLERANCES DECIMALS: X ± .1 XX ± .01 XXX ± .001 XXXX ± .0005 ANGULAR: X ± 0.5 THIRD ANGLE PROJECTION	DESIGNED BY: BUMPHREY	CREATION DATE: 9/9/2013	HYDRA POOLS	
	VOLUME: 9611330.770 Inch³		DETAILED BY: BUMPHREY	DETAILED DATE: 1/8/2018		
	COLOR: NA		LAST REVISED BY: bumphrey	LAST REVISED DATE: 1/8/2018	TITLE: LAYOUT, 20' X 45' X 40', TEE, 2' RADIUS, 8' DEEP, HS110N, LIGHT, 3-1084, 3-INLET, 600 SERIES	
	HEAT TREAT: NA		MATERIAL: Water	PART NUMBER: 00017153		
FINISH: NA					SHEET: 2 OF 4	
TEXTURE: NA						

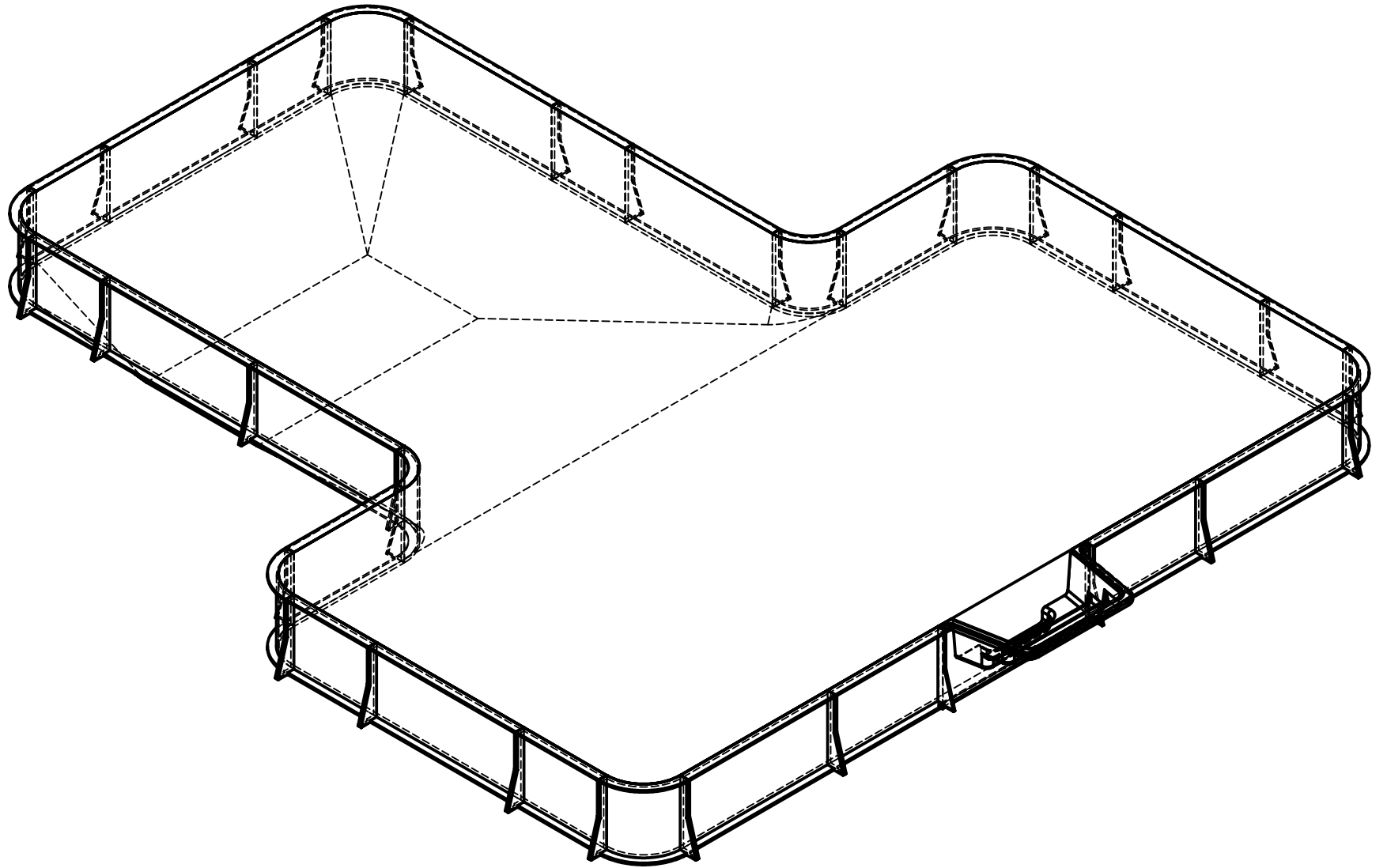

ENGINEERING DRAWING NUMBER: 00017153	WEIGHT: 471264.5 lbs	UNLESS OTHERWISE SPECIFIED DIMENSIONS ARE IN INCHES TOLERANCES DECIMALS: X ± .1 XX ± .01 XXX ± .001 XXXX ± .0005 ANGULAR: X ± 0.5 THIRD ANGLE PROJECTION 	DESIGNED BY: BUMPHREY	CREATION DATE: 9/9/2013	HYDRA POOLS	
	VOLUME: Inch³		DETAILED BY: BUMPHREY	DETAILED DATE: 1/8/2018		
	COLOR:		LAST REVISED BY: bumphrey	LAST REVISED DATE: 1/8/2018		
	HEAT TREAT:		MATERIAL:		TITLE: LAYOUT, 20' X 45' X 40', TEE, 2' RADIUS, 8' DEEP, HS110N, LIGHT, 3-1084, 3-INLET, 600 SERIES	
	FINISH:				PART NUMBER:	
	TEXTURE:				00017153	
				SCALE: 1:192	SIZE: A	
				SHEET: 3 OF 4		

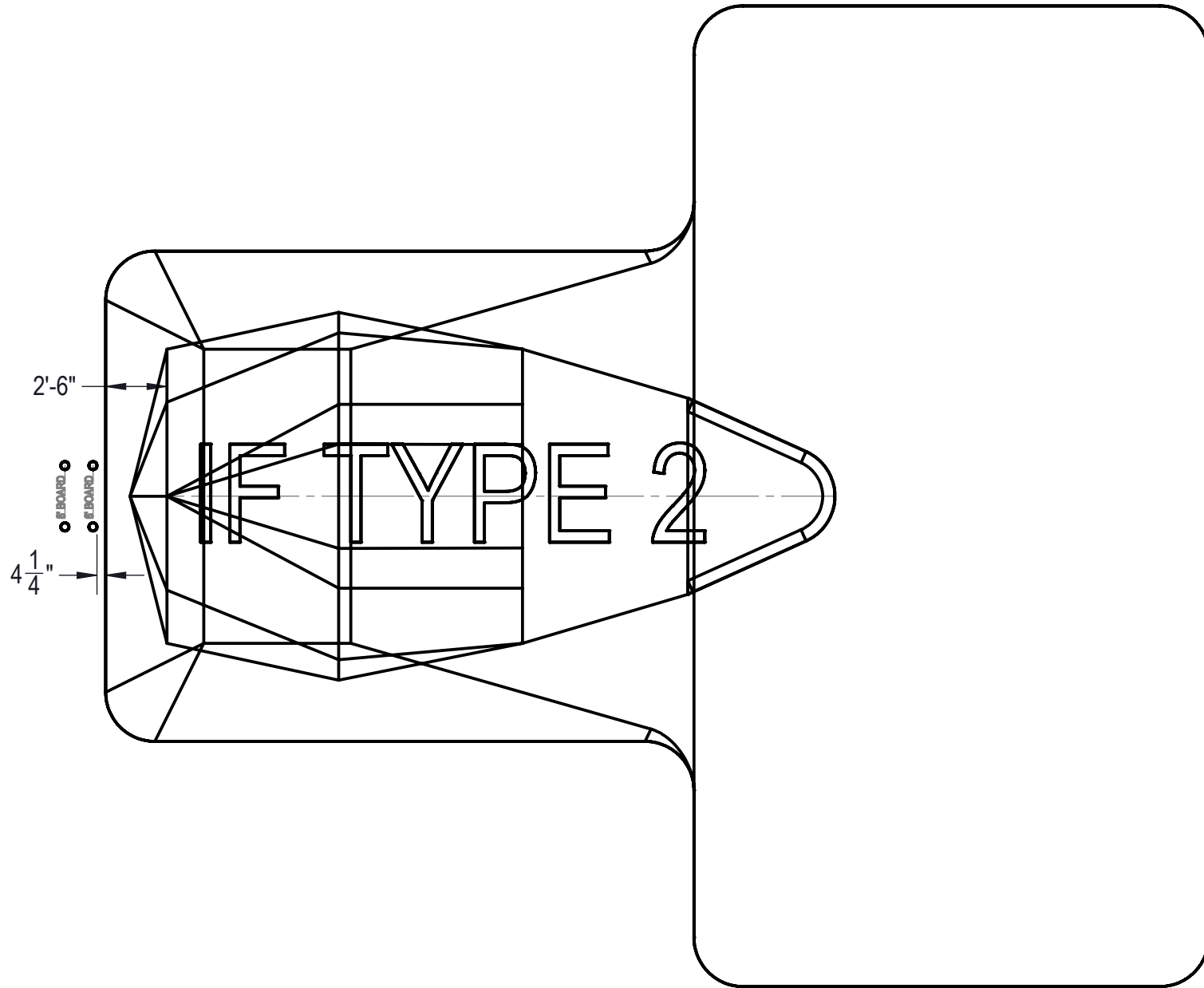

ENGINEERING DRAWING NUMBER: 00017153	WEIGHT: 471264.5 lbs	UNLESS OTHERWISE SPECIFIED DIMENSIONS ARE IN INCHES TOLERANCES DECIMALS: X ± .1 XX ± .01 XXX ± .001 XXXX ± .0005 ANGULAR: X ± 0.5 THIRD ANGLE PROJECTION 	DESIGNED BY: BUMPHREY	CREATION DATE: 9/9/2013	HYDRA POOLS	
	VOLUME: Inch ³		DETAILED BY: BUMPHREY	DETAILED DATE: 1/8/2018		
	COLOR:		LAST REVISED BY: bumphrey	LAST REVISED DATE: 1/8/2018		
	HEAT TREAT:		MATERIAL:		TITLE: LAYOUT, 20' X 45' X 40', TEE, 2' RADIUS, 8' DEEP, HS110N, LIGHT, 3-1084, 3-INLET, 600 SERIES	
	FINISH:		PART NUMBER:		00017153	
	TEXTURE:		SCALE: 1:192			
			SHEET: 4 OF 4			