

| REVISION HISTORY |             |      |     |    |
|------------------|-------------|------|-----|----|
| REV.             | DESCRIPTION | DATE | ECO | BY |
|                  |             |      |     |    |

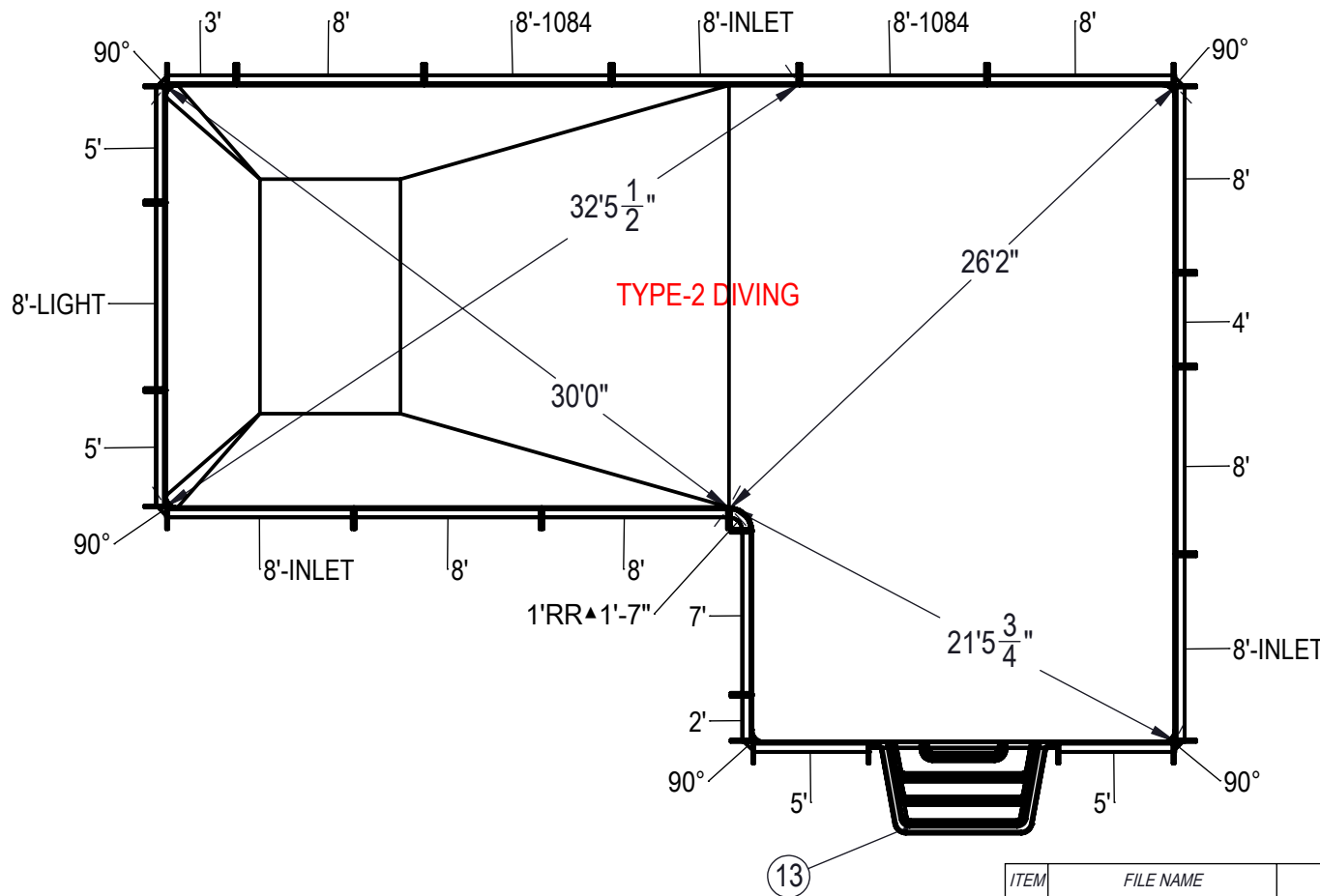

**NOTES:**

- THESE ARE FINISHED DIMENSIONS READY FOR THE LINER.
- DIMENSIONS ARE FROM INSIDE POOL PANELS.
- ROPE AND FLOAT ASSEMBLY SHOULD BE INSTALLED IN ACCORDANCE WITH CURRENT ANSI/ASPS/ICC REGULATIONS
- HYDRA LINER TRACK FOR STEPS IS INSTALLED WITH THE BARB FACING THE RISER WALL ON THE STEP.

**EXCAVATION NOTES:**

- ROUGH EXCAVATION SHOULD BE 2" DEEPER IN EACH INSTANCE.
- SOIL TO HAVE MINIMUM BEARING CAPACITY OF 1500 PSF.
- LOCATE TOP OF POOL AT LEAST 6" ABOVE THE SURROUNDING LAND ELEVATION.
- SEE "OVER DIG DETAIL" FOR EXCAVATION AROUND POOL.
- FILL VOIDS UNDER BASE OF PANELS AND TAMP WELL.
- BACK FILL WITH NON-EXPANSIVE MATERIAL.
- FOLLOW ALL CURRENT ANSI / APSP / ICC GUIDELINES FOR RESIDENTIAL POOLS

**IMPORTANT NOTES:**

THIS DOCUMENT IS FOR ILLUSTRATIVE PURPOSES ONLY. THE DEALER OR CONTRACTOR WHO SELLS OR INSTALLS YOUR POOL IS AN INDEPENDENT CONTRACTOR AND IS NOT AN AGENT OF THE MANUFACTURER. THE CONSTRUCTION METHODS ILLUSTRATED HERE ARE SUGGESTIONS AND APPLY ONLY TO NORMAL GROUND CONDITIONS. THERE MAY BE ADDITIONAL PRECAUTIONS AND/OR METHODS OF CONSTRUCTION. PROPER INSTALLATION IS THE RESPONSIBILITY OF THE DEALER/BUILDER/CONTRACTOR.

| ITEM | FILE NAME       | DESCRIPTION   | CUSTOMER DRAWING # | VENDOR PART # | QTY. |
|------|-----------------|---|--------------------|---------------|------|
| 1    | BOLT, PACK      | BOLT, FLANGE, 3/8-16 X 1", PACK (50)                        | HPS1916            | HPS1916       | 7    |
| 2    | SBRACE          | BRACE, FOLD OVER WITH TURNBUCKLE, STEEL, HPSFOB             | HPSFOB             | HPSFOB        | 27   |
| 3    | PANEL, RR       | PANEL, 1" REVERSE RADIUS, 90° ANGLE, 1'-7" LONG, 600 SERIES | HPSCRR2            | 00002221      | 1    |
| 4    | PANEL, STRAIGHT | PANEL, 2' LONG, 600 SERIES                                  | HPSPD102P          | 00000621      | 1    |
| 5    | PANEL, STRAIGHT | PANEL, 3' LONG, 600 SERIES                                  | HPSPD103P          | 00000643      | 1    |
| 6    | PANEL, STRAIGHT | PANEL, 4' LONG, 600 SERIES                                  | HPSPD104P          | 00000274      | 1    |
| 7    | PANEL, STRAIGHT | PANEL, 5' LONG, 600 SERIES                                  | HPSPD105P          | 00000674      | 4    |
| 8    | PANEL, STRAIGHT | PANEL, 7' LONG, 600 SERIES                                  | HPSCS8             | 0010126       | 1    |
| 9    | PANEL, STRAIGHT | PANEL, 8' LONG, 1084, 600 SERIES                            | HPSPD10884         | 00002006      | 2    |
| 10   | PANEL, STRAIGHT | PANEL, 8' LONG, 600 SERIES                                  | HPSPD108P          | 00000687      | 6    |
| 11   | PANEL, STRAIGHT | PANEL, 8' LONG, INLET, 600 SERIES                           | HPSPD108I          | 00000699      | 3    |
| 12   | PANEL, STRAIGHT | PANEL, 8' LONG, LIGHT, 600 SERIES                           | HPSPD108L          | 00000701      | 1    |
| 13   | HS110N          | STEP, 8", TWIN SEAT, 4 TREAD                                | HS110N             | HS110N        | 1    |
| 14   | PANEL, WEDGE    | WEDGE, 2 1/2" X 2 1/2" X 90°-600-ASSEMBLY                   | HPSPD6CA           | 00005721      | 5    |

|  |                          |   |
|--|--------------------------|---|
| ENGINEERING DRAWING NUMBER:<br><b>00017354</b> | WEIGHT:<br>382663.72 lbs | <b>UNLESS OTHERWISE SPECIFIED</b><br>DIMENSIONS ARE IN INCHES<br>TOLERANCES<br>DECIMALS: X ± .1<br>XX ± .01<br>XXX ± .001<br>XXXX ± .0005<br><br>ANGULAR: X ± 0.5<br>THIRD ANGLE PROJECTION |
|  | VOLUME:<br>Inch³         |   |
|  | COLOR:                   |   |
|  | HEAT TREAT:              |   |
|  | FINISH:                  |   |
|  | TEXTURE:                 |   |

|                                    |                                 |
|------------------------------------|---------------------------------|
| DESIGNED BY:<br><b>BUMPHREY</b>    | CREATION DATE:<br>10/5/2011     |
| DETAILED BY:<br><b>RSANVICENTE</b> | DETAILED DATE:<br>1/23/2018     |
| LAST REVISED BY:<br><b>hyeng</b>   | LAST REVISED DATE:<br>1/23/2018 |
| MATERIAL:                          |                                 |

|  |   |
|--|---|
| <b>HYDRA POOLS</b>   |   |
| TITLE: LAYOUT, 18' X 43' X 28', TRUE L, LEFT, 6" RADIUS, 8' DEEP, HS110N, LIGHT, 3- INLET, 2- 1084, 600 SERIES |   |
| PART NUMBER:<br><b>00017354</b>  | SCALE: 1:192<br>SHEET: 1 OF 4<br>SIZE: <b>A</b> |

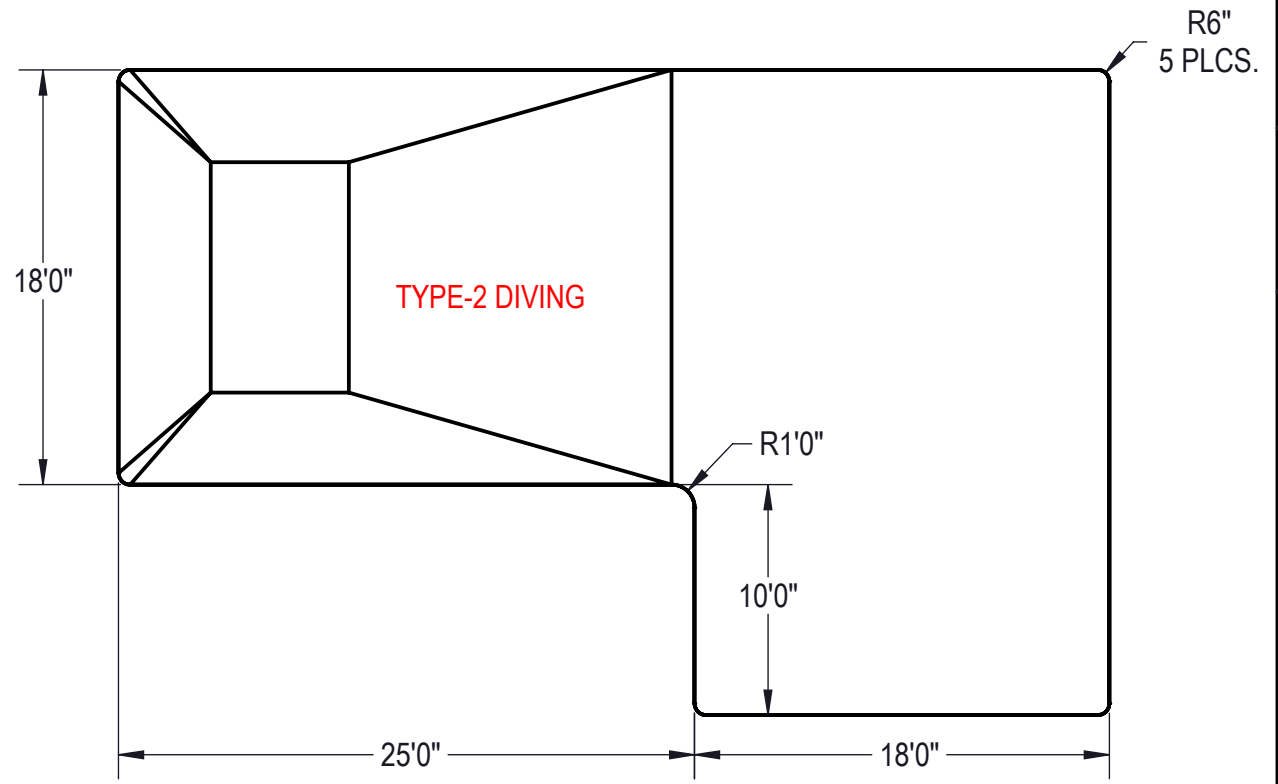
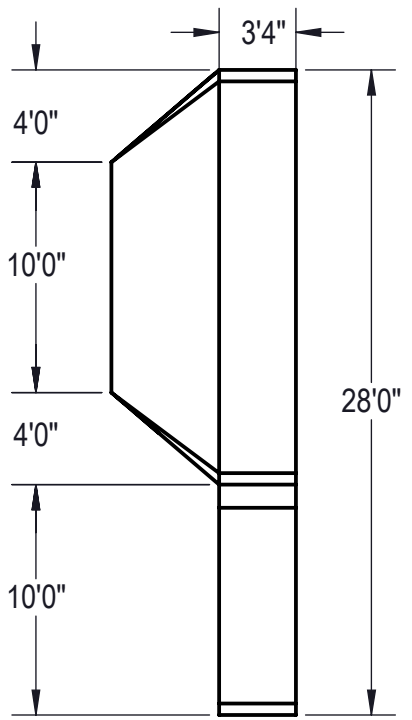

**Area: 953.95ft ^2**  
**Perimeter: 140.50ft**  
**Volume = 31535 US gallons**

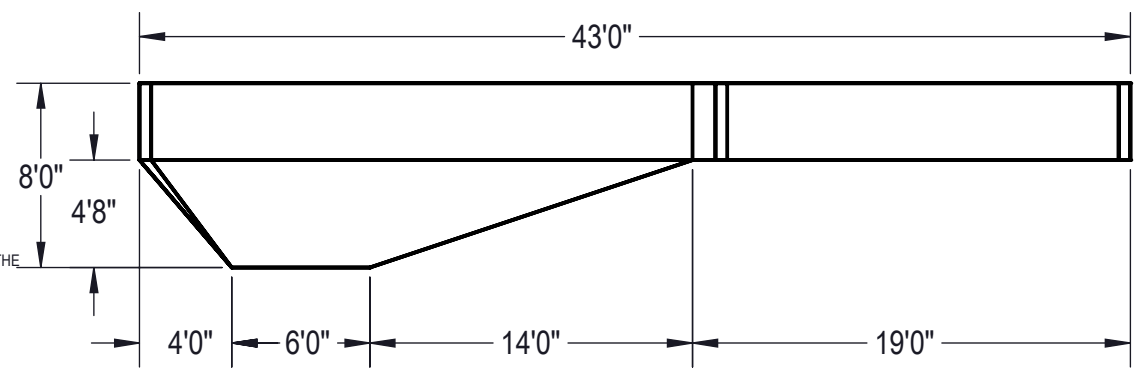

**NOTES:**

1. THESE ARE FINISHED DIMENSIONS READY FOR THE LINER.
2. DIMENSIONS ARE FROM INSIDE POOL PANELS.
3. ROPE AND FLOAT ASSEMBLY SHOULD BE INSTALLED IN ACCORDANCE WITH CURRENT ANSI/ASPS/ICC REGULATIONS
4. HYDRA LINER TRACK FOR STEPS IS INSTALLED WITH THE BARB FACING THE RISER WALL ON THE STEP.

**EXCAVATION NOTES:**

5. ROUGH EXCAVATION SHOULD BE 2" DEEPER IN EACH INSTANCE.
6. SOIL TO HAVE MINIMUM BEARING CAPACITY OF 1500 PSF.
7. LOCATE TOP OF POOL AT LEAST 6" ABOVE THE SURROUNDING LAND ELEVATION.
8. SEE "OVER DIG DETAIL" FOR EXCAVATION AROUND POOL.
9. FILL VOIDS UNDER BASE OF PANELS AND TAMP WELL.
10. BACK FILL WITH NON-EXPANSIVE MATERIAL.
11. FOLLOW ALL CURRENT ANSI / ASP / ICC GUIDELINES FOR RESIDENTIAL POOLS

**IMPORTANT NOTES:**

THIS DOCUMENT IS FOR ILLUSTRATIVE PURPOSES ONLY. THE DEALER OR CONTRACTOR WHO SELLS OR INSTALLS YOUR POOL IS AN INDEPENDENT CONTRACTOR AND IS NOT AN AGENT OF THE MANUFACTURER. THE CONSTRUCTION METHODS ILLUSTRATED HERE ARE SUGGESTIONS AND APPLY ONLY TO NORMAL GROUND CONDITIONS. THERE MAY BE ADDITIONAL PRECAUTIONS AND/OR METHODS OF CONSTRUCTION. PROPER INSTALLATION IS THE RESPONSIBILITY OF THE DEALER/BUILDER/CONTRACTOR.

|  |                                |   |                                       |                                 |  |  |
|--|--------------------------------|---|---------------------------------------|---------------------------------|--|--|
| ENGINEERING DRAWING NUMBER:<br><b>00017354</b> | WEIGHT:<br>119374038.12        | <b>UNLESS OTHERWISE SPECIFIED</b><br>DIMENSIONS ARE IN INCHES<br>TOLERANCES<br>DECIMALS: X ± .1<br>XX ± .01<br>XXX ± .001<br>XXXX ± .0005<br><br>ANGULAR: X ± 0.5<br>THIRD ANGLE PROJECTION | DESIGNED BY:<br>BUMPHREY              | CREATION DATE:<br>2/19/2013     | <b>HYDRA POOLS</b>   |  |
|  | lbs VOLUME:<br>119374038121.73 |   | DETAILED BY:<br>RSANVICENTE           | DETAILED DATE:<br>1/23/2018     |  |  |
|  | inch COLOR:<br>NA              |   | LAST REVISED BY:<br>hyeng             | LAST REVISED DATE:<br>1/23/2018 | TITLE: LAYOUT, 18' X 43' X 28', TRUE L, LEFT, 6" RADIUS, 8' DEEP, HS110N, LIGHT, 3- INLET, 2- 1084, 600 SERIES |  |
|  | HEAT TREAT:<br>NA              |   | MATERIAL:<br>Material <not specified> |                                 |  |  |
| FINISH:<br>NA                                  |                                |   |                                       |                                 | SHEET:<br>2 OF 4   |  |
| TEXTURE:<br>NA                                 |                                |   |                                       |                                 |  |  |

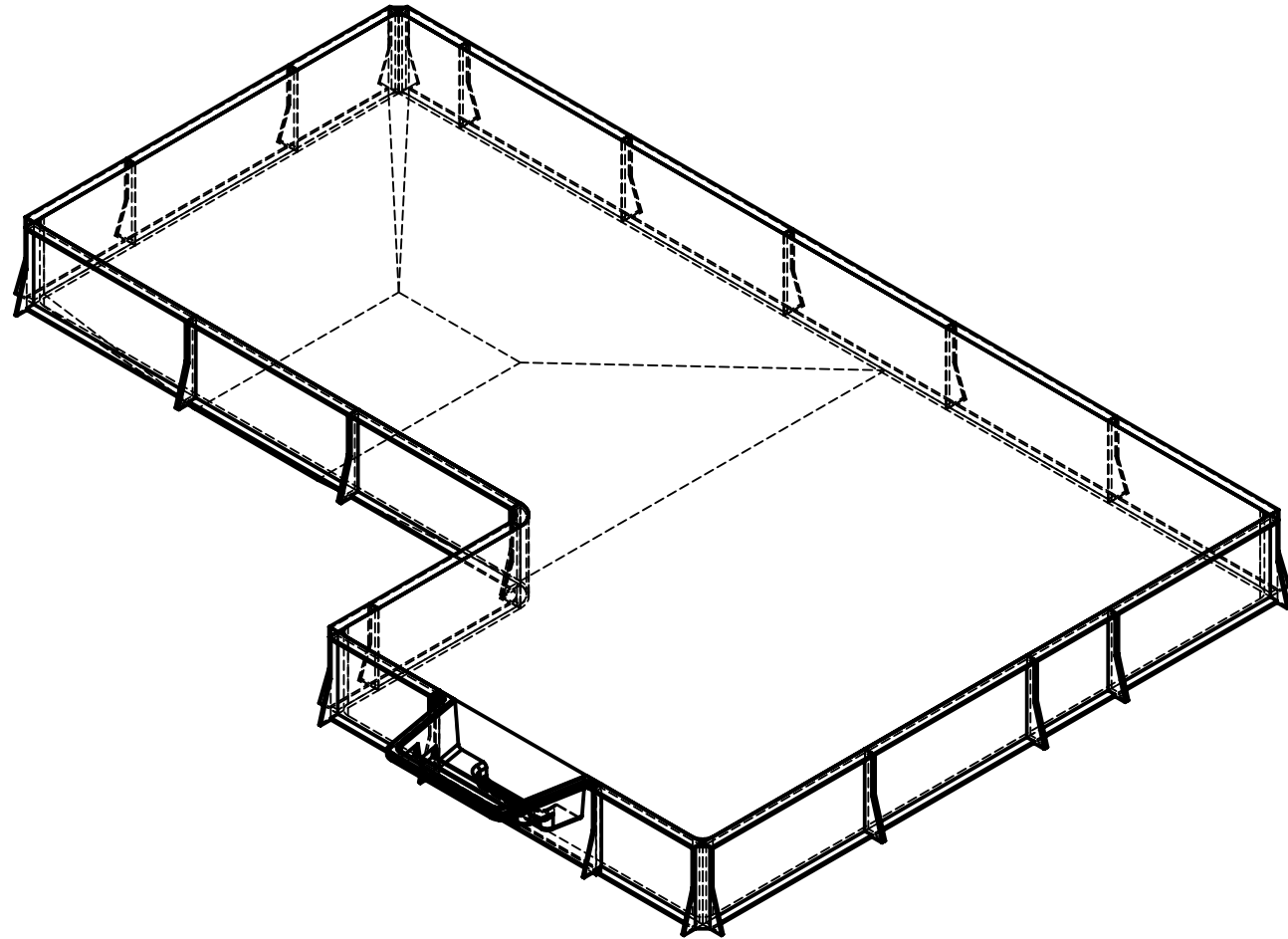

|  |                              |   |                                 |                                 |   |          |
|--|------------------------------|---|---------------------------------|---------------------------------|---|----------|
| ENGINEERING DRAWING NUMBER:<br><b>00017354</b> | WEIGHT:<br>382663.72 lbs     | <b>UNLESS OTHERWISE SPECIFIED</b><br>DIMENSIONS ARE IN INCHES<br>TOLERANCES<br>DECIMALS: X ± .1<br>XX ± .01<br>XXX ± .001<br>XXXX ± .0005<br><br>ANGULAR: X ± 0.5<br>THIRD ANGLE PROJECTION<br> | DESIGNED BY:<br>BUMPHREY        | CREATION DATE:<br>10/5/2011     | <b>HYDRA POOLS</b><br><br>TITLE: LAYOUT, 18' X 43' X 28', TRUE L, LEFT, 6" RADIUS, 8' DEEP,<br>HS110N, LIGHT, 3- INLET, 2- 1084, 600 SERIES |          |
|  | VOLUME:<br>Inch <sup>3</sup> |   | DETAILED BY:<br>RSANVICENTE     | DETAILED DATE:<br>1/23/2018     |   |          |
|  | COLOR:                       |   | LAST REVISED BY:<br>hyeng       | LAST REVISED DATE:<br>1/23/2018 |   |          |
|  | HEAT TREAT:                  |   | MATERIAL:                       |                                 |   |          |
|  | FINISH:                      |   | PART NUMBER:<br><b>00017354</b> |                                 | SCALE:<br>1:128   | <b>A</b> |
|  | TEXTURE:                     |   |                                 |                                 | SHEET:<br>3 OF 4  |          |

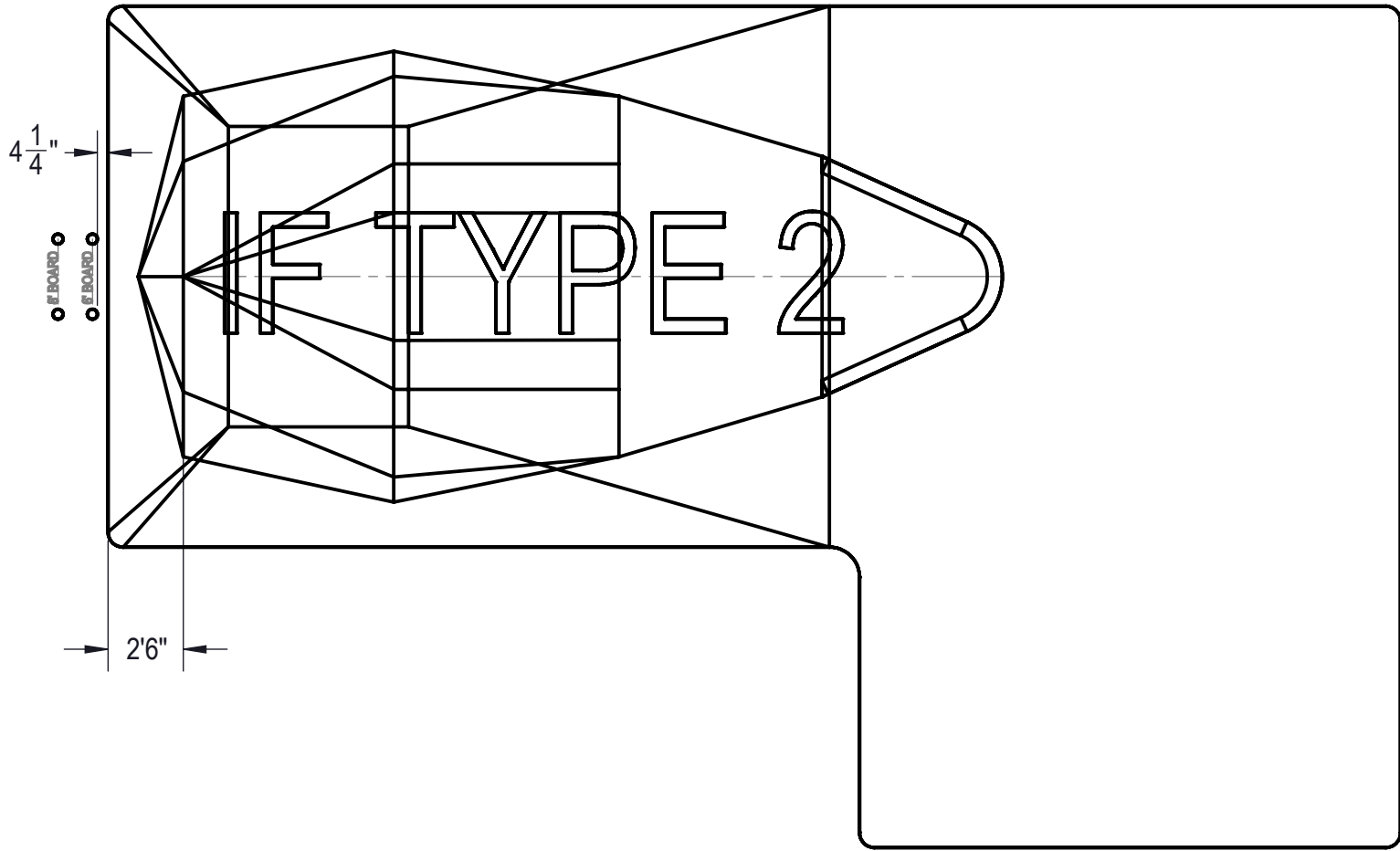

|  |                          |   |                             |                                 |  |                  |            |
|--|--------------------------|---|-----------------------------|---------------------------------|--|------------------|------------|
| ENGINEERING DRAWING NUMBER:<br><b>00017354</b> | WEIGHT:<br>382663.72 lbs | <b>UNLESS OTHERWISE SPECIFIED</b><br>DIMENSIONS ARE IN INCHES<br>TOLERANCES<br>DECIMALS: X ± .1<br>XX ± .01<br>XXX ± .001<br>XXXX ± .0005<br><br>ANGULAR: X ± 0.5<br>THIRD ANGLE PROJECTION<br> | DESIGNED BY:<br>BUMPHREY    | CREATION DATE:<br>10/5/2011     | HYDRA POOLS<br><br>TITLE: LAYOUT, 18' X 43' X 28', TRUE L, LEFT, 6" RADIUS, 8' DEEP,<br>HS110N, LIGHT, 3- INLET, 2- 1084, 600 SERIES |                  |            |
|  | VOLUME:<br>Inch³         |   | DETAILED BY:<br>RSANVICENTE | DETAILED DATE:<br>1/23/2018     |  |                  |            |
|  | COLOR:                   |   | LAST REVISED BY:<br>hyeng   | LAST REVISED DATE:<br>1/23/2018 |  |                  |            |
|  | HEAT TREAT:              |   | MATERIAL:                   |                                 | PART NUMBER:   | SCALE:<br>1:128  | SIZE:<br>A |
|  | FINISH:                  |   |                             |                                 | <b>00017354</b>  | SHEET:<br>4 OF 4 |            |
|  | TEXTURE:                 |   |                             |                                 |  |                  |            |